

# INSTALLATION INSTRUCTIONS

Facade panels

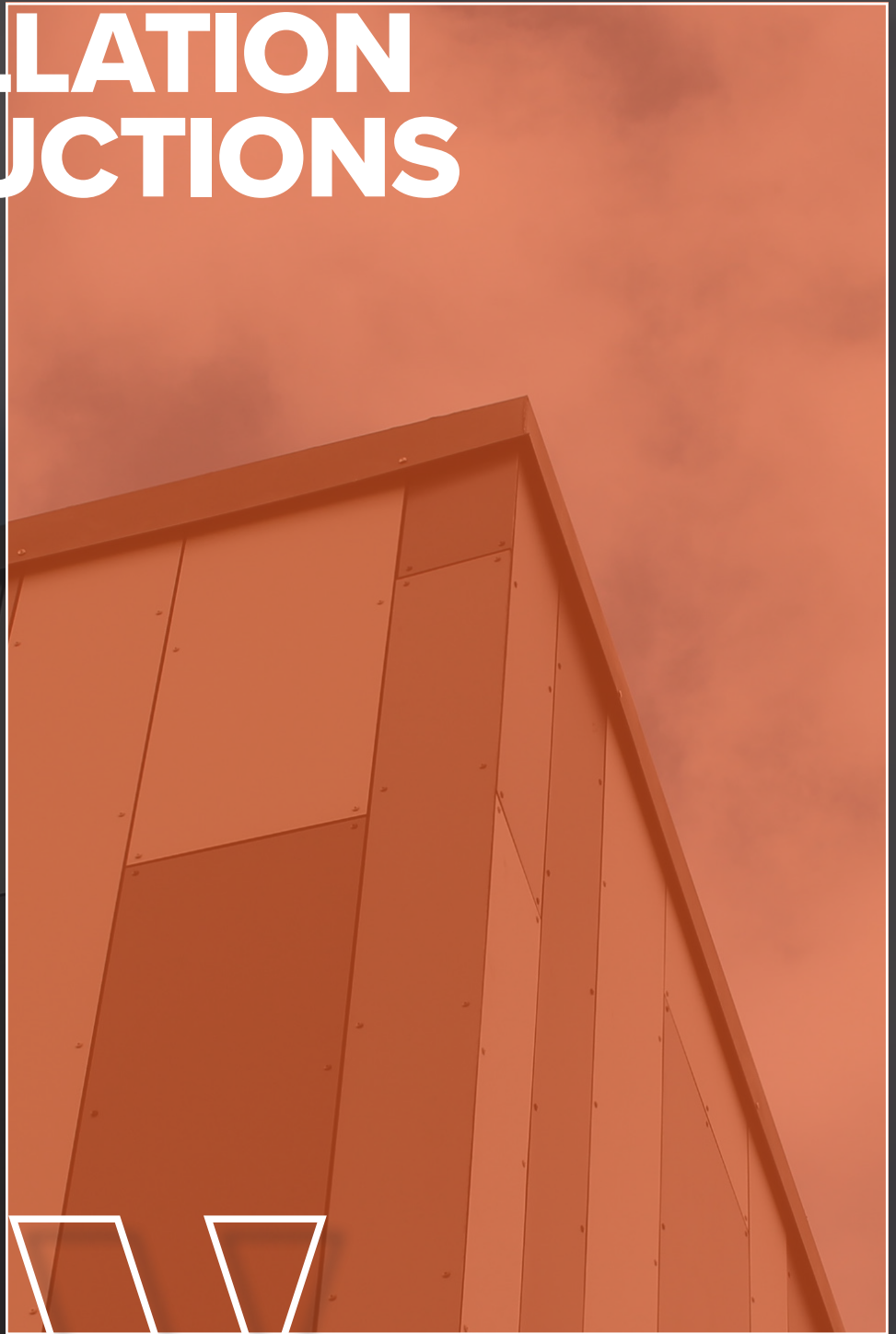

Modern facades  
designed for Scandinavian  
weather and construction

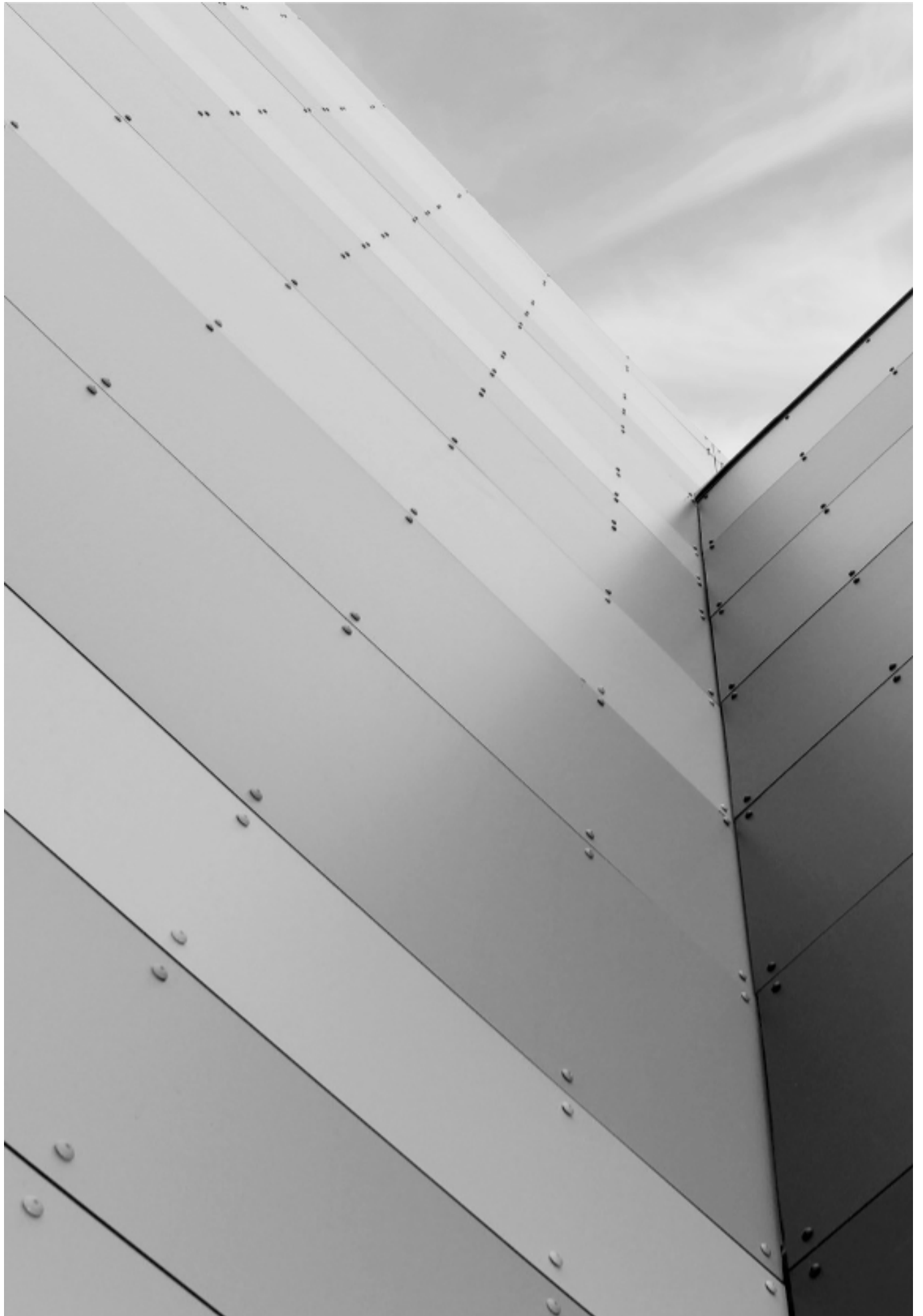

# INDHOLD

## **1. PRODUCTS** **2**

---

- 2 Frontline Light
- 3 Frontline Duo
- 3 Frontline Color

## **2. WARRANTY** **4**

---

## **3. HANDLING, TRANSPORT, AND STORAGE** **4**

---

## **4. STRUCTURES** **5**

---

- 5 Wood
- 5 Steel
- 5 General
- 5 Hole and screw guide

## **5. INSTALLATION** **6**

---

- 6 Protective film
- 6 Cutting
- 6 Drilling
- 6 Screwing
- 6 Drilling & mounting

## **6. ACCESSORIES** **7**

---

- 7 Facade screws and accessories
- 7 Aluminum coverings

## **7. WORK SAFELY WITH COMPACT LAMINATE** **7**

---

# 1. PRODUCTS

Stylish appearance and a solid core - that describes our Frontline facade panels.

Both factors are important - especially for outdoor use as weather protection.

Frontline meets high-quality standards, after all, it's about protecting building.

The visual impression of a building is also of great importance, which is why design quality is just as important as product quality. Our Frontline compact laminate panels are developed to meet both needs, offering uncompromising durability and consistent protection.

Walltec's Frontline compact laminate facade cladding provides you with countless options for beautiful and durable facades. Frontline compact laminate is particularly suitable as the primary weather barrier in ventilated facade constructions, usable at all heights, and as a decorative interior panel where high demands for stability and durability against moisture are required.

## **Walltec facade panels can be used for:**

- Exterior walls and weather protection
- Balconies and balconies
- Gables and dormers
- Overhangs
- Windows and window sills
- Fascia and parapets

## **There are three different variants of our Frontline facade panel:**

- Frontline Light
- Frontline Duo
- Frontline Color

# FRONTLINE LIGHT

Walltec Frontline Light is a solid-colored compact laminate panel, available in light colors.

A 10-year guarantee is provided for color fastness according to DS/EN 20105-A02:1994.

Find warranty certificate and provisions on our website [www.walltec.co](http://www.walltec.co)

## Material

Walltec Frontline Light is a panel of hard-pressed kraft paper, bound together by phenolic resin, with decorative paper and lamination applied to the outer sides. Due to this construction, the Walltec Frontline panel is sealed in both core and surface. This prevents moisture and living organisms from penetrating the panel.

## Application

Primary weather barrier in ventilated facade constructions. Suitable for all heights, and as a decorative interior panel where high durability against moisture is required.

- Exterior walls - facade panels
- Interior spaces and partitions
- Balconies
- Gables and dormers
- All types of panels
- Overhangs
- Windows and sills
- Fascia and parapets

## Environment

In our production, all necessary procedures are employed to ensure the best environmental performance and sustainability. For example, a minimum of 20% recycled paper is used in the production of laminate, and all other materials are sourced only from FSC-approved manufacturers.

## Construction

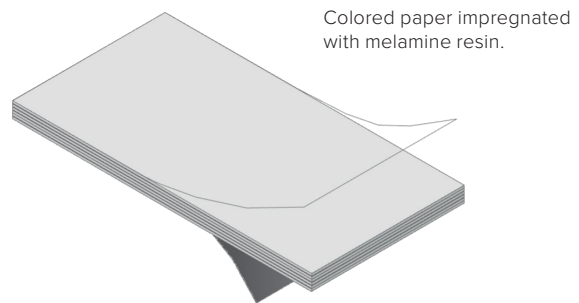

1430 psi at 150 degrees.

## Shaping

Frontline is supplied as standard in 6 mm thickness and dimensions of 1300 x 3050 mm. For other thicknesses or dimensions, you can use a Frontline Color. Walltec Frontline Light comes with a dark brown core.

## Colors

Standard colors:

- White RAL 9010
- Light gray RAL 7035

# FRONTLINE DUO UV+

Walltec Frontline Duo UV+ is a 2-colored compact laminate panel. The panel comes with a UV film, and therefore, a 10-year guarantee is provided for color fastness according to DS/EN 20105-A02:1994. Find warranty certificate and provisions on our website [www.walltec.co](http://www.walltec.co).

## Material

Walltec Frontline Duo UV+ is a panel of hard-pressed kraft paper, bound together by phenolic resin, with decorative paper and lamination applied to the outer sides. Due to this construction, the Walltec Frontline panel is sealed in both core and surface, preventing moisture and living organisms from penetrating the panel.

## Application

Primary weather barrier in ventilated facade constructions. Suitable for all heights, and as a decorative interior panel where high durability against moisture is required.

- Exterior walls - facade panels
- Interior spaces and partitions
- Balconies
- Gables and dormers
- All types of panels
- Overhangs
- Windows and sills
- Fascia and parapets

## Environment

In our production, all necessary procedures are implemented to ensure the best environmental performance and sustainability. For example, a minimum of 20% recycled paper is used in the production of laminate, and all other materials are sourced only from FSC-approved manufacturers.

## Construction

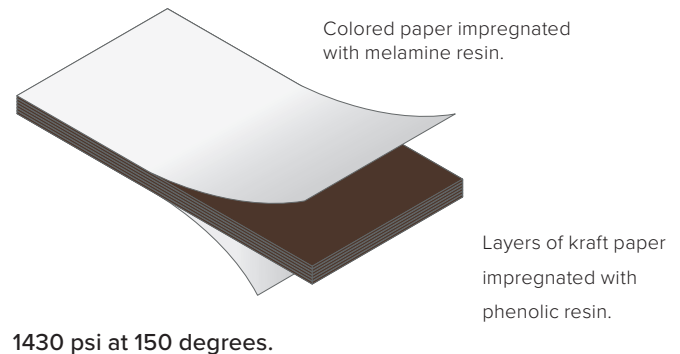

## Shaping

Frontline is supplied standard in 6 mm thickness, and dimensions of 1300 x 3050 mm. In addition to our standard range, other thicknesses or dimensions can be supplied (1-30 mm). Walltec Frontline Duo UV+ comes with a dark brown core.

## Colors

Standard colors:

- Black RAL 9005 and light gray RAL 7035
- Anthracite RAL 7016 and white RAL 9010

# FRONTLINE COLOR UV+



Walltec Frontline COLOR UV+ is a solid-colored compact laminate panel. The panel comes with a UV film, and therefore, a 10-year guarantee is provided for color fastness according to DS/EN 20105-A02:1994. Find warranty certificate and provisions on our website [www.walltec.co](http://www.walltec.co).

## Material

Walltec Frontline Color UV+ is a panel of hard-pressed kraft paper, bound together by phenolic resin, with decorative paper and lamination applied to the outer sides. Due to this construction, the Walltec Frontline panel is sealed in both core and surface, preventing moisture and living organisms from penetrating the panel.

## Application

Primary weather barrier in ventilated facade constructions. Suitable for all heights, and as a decorative interior panel where high durability against moisture is required.

- Exterior walls - facade panels
- Interior spaces and partitions
- Balconies
- Gables and dormers
- All types of panels
- Overhangs
- Windows and sills
- Fascia and parapets

## Environment

In our production, all necessary procedures are employed to ensure the best environmental performance and sustainability. For example, a minimum of 20% recycled paper is used in the production of laminate, and all other materials are sourced only from FSC-approved manufacturers.

## Construction

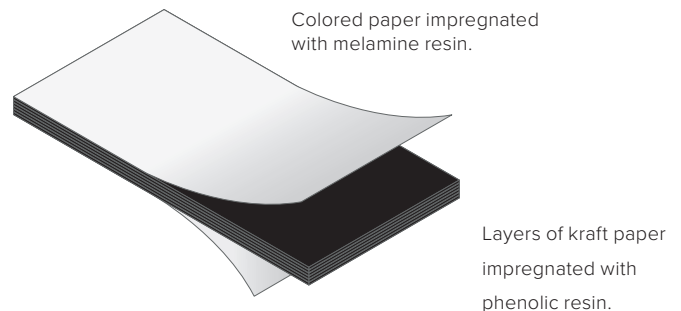

1430 psi at 150 degrees.

## Shaping

Frontline is supplied standard in 6 mm thickness, and dimensions of 1300 x 3050 mm. In addition to our standard range, other thicknesses or dimensions can be supplied (1-30 mm). Walltec Frontline Color UV+ comes with a black core.

## Colors

Standard colors:

- Black RAL 9005
- Anthracite RAL 7016

Frontline COLOR is available in 40 standard colors according to the color chart.

## **2. WARRANTY**

On Walltec Frontline facade panels, a product warranty is provided for a period of 10 years if they are correctly installed according to the supplier's instructions. On the same panels with UV+ film, a color guarantee of 10 years is also provided according to DS/EN 20105 (gray scale). See warranty certificate at [www.walltec.co](http://www.walltec.co). Furthermore, please refer to Walltec's terms of sale and delivery, installation instructions, datasheets, etc. on our website [www.walltec.co](http://www.walltec.co).



### 3. HANDLING, TRANSPORT, AND STORAGE

To avoid damaging the surfaces and edges, panels must be handled carefully. Despite the excellent surface hardness, the weight/stacking weight of the panels can be a possible cause of damage. Therefore, all forms of impurities between the panels must be avoided. Walltec facade panels should always be transported with a focus on preventing the panels from slipping, and they should be secured during transport. During installation, panels should always be lifted by two people.

#### Storage and Handling

- Remove transport packaging from panels and pallet.
- Store dry, under cover, not exposed to frost, rain, or sunlight.
- Store horizontally and symmetrically stacked.
- Panels must be lifted from the stack - not dragged or pushed.
- Panels should be transported on pallets in the specified dimensions.
- If using multiple pallets, they should only be stacked on top of each other using a cover plate.
- Panels must be stored dry on the construction site, under cover, not exposed to sunlight, rain, or frost.
- Always ensure good ventilation around the panels.
- Panels must acclimatize for a minimum of 24 hours before installation.
- Panels should not be placed against other building components for an extended period, as they may deform or become curved.

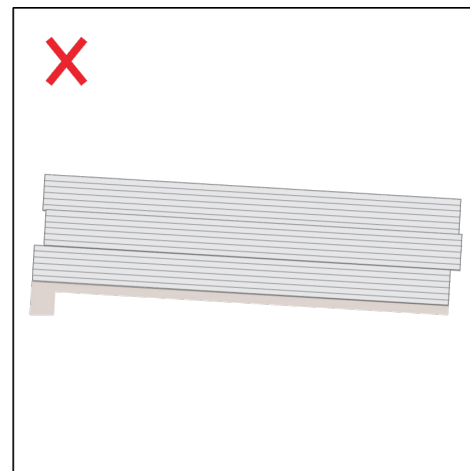
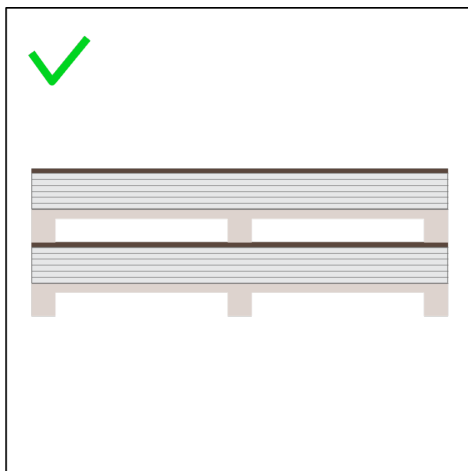

Store horizontally and symmetrically stacked.

Panels must be transported on pallets in the specified dimensions.

If using multiple pallets, they should only be stacked on top of each other using a cover plate between the pallets.

# 4. CONSTRUCTIONS

## Wood:

- Maximum center-to-center distance horizontally between battens is 400-550mm - see screwing instructions.
- Always use pressure-treated and planed battens if wood substrates are used.
- The construction must be ventilated with a minimum of 22 mm. Always ensure free access for ventilation at ground level, under windowsills, roofs, etc.
- Always use EPDM tape between the panel and the battens.
- Minimum 8 mm gap in both horizontal and vertical panel joints.

## Steel:

- Maximum center-to-center distance horizontally between battens is 400-550mm - see screwing instructions.
- Always use pressure-treated and planed battens if steel profiles are used.
- The construction must be ventilated with a minimum of 22 mm. Always ensure free access for ventilation at ground level, under windowsills, roofs, etc.
- Always use EPDM tape between the panel and the steel profile.
- Minimum 8 mm gap in both horizontal and vertical panel joints.

## General:

- Always ensure adequate ventilation behind Walltec panels - best achieved with planed battens at least 22 mm thick.
- Always use EPDM tape under the panels.
- Minimum distance to ground level is 100 mm.

## Hole and screwing instructions:

Always ensure the appropriate screwing torque when installing Walltec facade panels. When mounting with Walltec facade screws, pre-drill with a 7 mm drill bit. Screw distance from edge at least 20 mm.

## Hul- og skrueafstand:

Example 1:

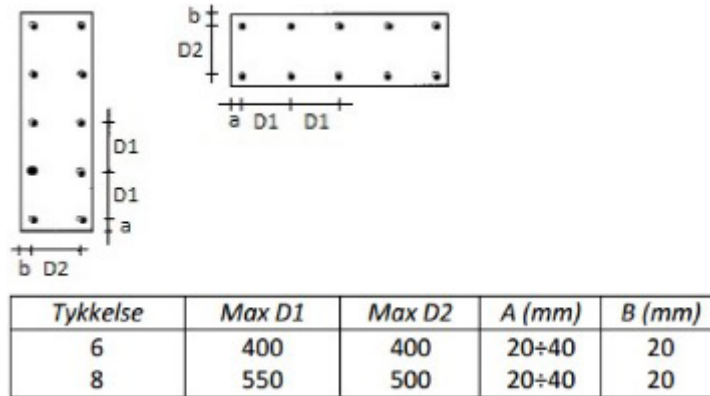

Example 2:

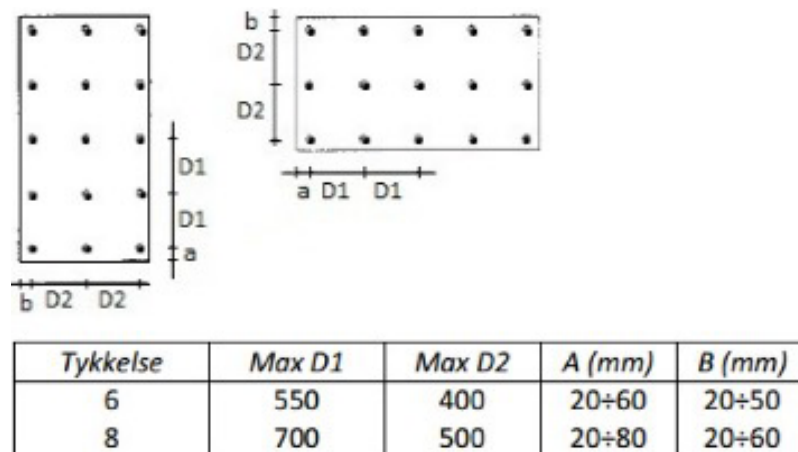

All panels are delivered in production format and require cutting to size. They are produced and delivered according to EN 438-2. In the production format, there may be rough-cut edges, and they cannot be expected to be square according to EN 438-2. Walltec offers cutting to fixed dimensions as well as pre-drilling of holes for an additional charge. Example 1 & 2 as seen above are ONLY for vertical installation. For horizontal installation of the panels, it is recommended that the maximum center-to-center distance (width & length measurements) is 420 mm.

## 2. INSTALLATION

### Protective film

- Walltec facade panels are delivered with protective film on one or both sides of the facade panel. In night-time, frosty, and damp conditions, or in case of moisture between the panels, there may be some adhesive residues on the panel. Therefore, we recommend removing the protective film as late in the workday as possible.
- Any adhesive residues on the panel can be removed according to our maintenance instructions.
- Protective film must be removed from both sides of the panel, and it is recommended to remove the protective film immediately before mounting the trimmed and pre-drilled panel.

### Cutting

- Walltec facade panels are delivered in production format and must be cut on all 4 sides. They are produced and delivered according to EN 438-2. In the production format, there may be rough-cut edges and cannot be expected to be at an angle.
- Use Walltec blade 160 × 2.0 / 1.2 × 20 / 40t for the circular saw.  
If another saw or blade is used, we recommend a fine-toothed hard metal blade.
- The saw settings should be for fine cuts.
- The cut edges do not need to be sealed or treated before installation, but can be chamfered with a file or sandpaper.

### Drilling

- Pre-drill screw holes to a minimum of 7 mm when using Walltec screws in size 4.8 × 29 mm. For other screw dimensions, the hole size should be screw thickness × 1.5. (E.g., 4.8 mm × 1.5 = minimum 7.2 mm hole)
- Always use hard metal drill bits.
- Always ensure full support when drilling into the panel.

### Screwing

- Place the screw in the center of the hole, ensuring that the fastening head is flush with the panel surface. The screw should be centered in the oversized holes to allow for panel movement.
- Optionally, use self-centering drill bits in the oversized holes.
- DO NOT tighten the screws too tightly.

## Preparation - drilling

Pre-drill screw holes with a minimum diameter of 7 mm when using Walltec screws sized  $4.8 \times 29$  mm. For other screw dimensions, the hole diameter should be screw thickness  $\times 1.5$  (e.g.,  $4.8 \text{ mm} \times 1.5 =$  minimum 7.2 mm hole). Always use carbide-tipped drill bits.

⚠ ALWAYS ENSURE FULL SUPPORT WHEN DRILLING INTO THE PANEL.

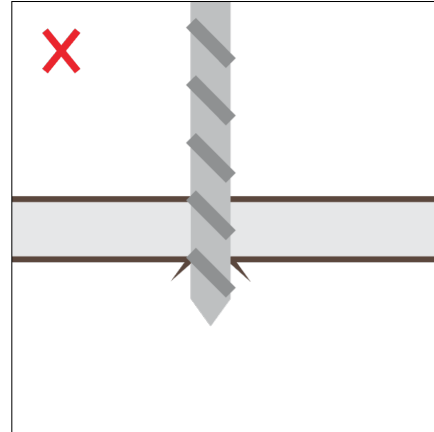
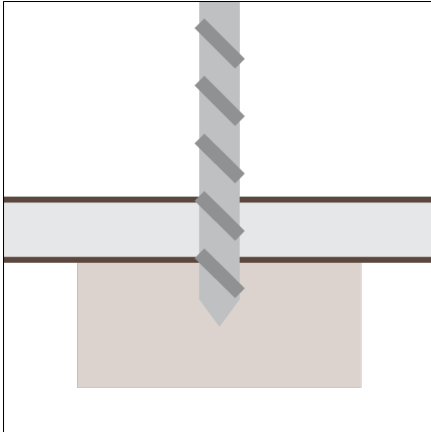

## Mounting

Always ensure sufficient ventilation behind Walltec panels – best achieved by using planed battens with a minimum thickness of 22 mm.

- Always use EPDM tape under the panels.
- Minimum distance to ground level is 100 mm.

⚠ THERE SHOULD ALWAYS BE GOOD VENTILATION. VERTICAL BATTENING

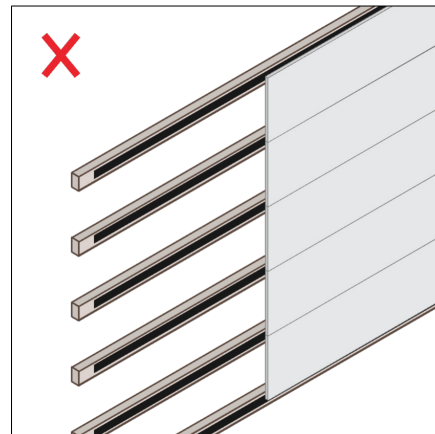
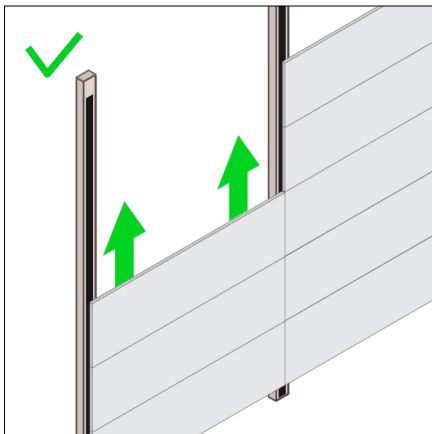

# 6. ACCESSORIES



## Facade screws and accessories:

Walltec offers colored facade screws that match the panels. The following standard screws are available in stock:

illustration	Screwdata	Color	Nearest RAL	Item nr.	DB nr.
	4,8 x 33 A2	Sort	RAL 9005	903190	1851560
		Antracit	RAL 7016	902633	1851557
		Hvid	RAL 9010	902262	1581558
		Lysegrå	RAL 7035	902209	1851559

When ordering special colors, screws in the same color can be provided. Walltec also stocks EPDM tape in 20 and 74 mm widths, as well as a saw blade of 160 mm/48t with a maximum of 10,000 rpm.

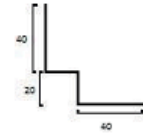
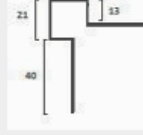
## Aluminum inlays:

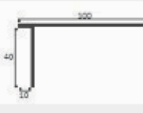
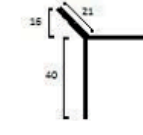
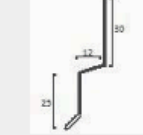
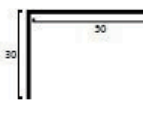
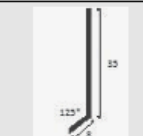
Edge- and corner profiles	Illustration	Length (m)	Thickness (mm)	Color	Item nr.	DB nr.
Internal corner		3,0	0,8	RAL 9005 Black	801013	1851563
				RAL 7016 Anthracite	801012	1851564
				RAL 9010 White	801011	1899784
				RAL 7035 Light gray	801014	1899782
External corner		3,0	0,8	RAL 9005 Black	802013	1851567
				RAL 7016 Anthracite	802012	1851568
				RAL 9010 White	802011	1899790
				RAL 7035 Light gray	802014	1899792
Vertical joint profile		3,0	0,8	RAL 9005 Black	803013	1899797
				RAL 7016 Anthracite	803012	1899796
				RAL 9010 White	803011	1899794
				RAL 7035 Light gray	803014	1899798
Reveal profile (door/window)		3,0	0,8	RAL 9005 Black	804013	1851565
				RAL 7016 Light gray	804012	1851566
				RAL 9010 White	804011	1899800
				RAL 7035 Light gray	804014	1899801
External corner cap		3,0	0,8	RAL 9005 Black	805013	1899804
				RAL 7016 Anthracite	805012	1899803
				RAL 9010 White	805011	1899802
				RAL 7035 Light gray	805014	1899805
Drip edge		3,0	0,8	RAL 9005 Black	806013	1851569
				RAL 7016 Anthracite	806012	1851570
				RAL 9010 White	806011	1899806
				RAL 7035 Light gray	806014	1899807
Ventilation profile		3,0	0,8	RAL 9005 Black	807013	1899810
				RAL 7016 Anthracite	807012	1899809
				RAL 9010 White	807011	1899808
				RAL 7035 Light gray	807014	1899811
Horizontal drip edge		3,0	0,8	RAL 9005 Black	809013	1899814
				RAL 7016 Anthracite	809012	1899813
				RAL 9010 White	809011	1899812
				RAL 7035 Light gray	809014	1899816

## **7. WORK SAFELY WITH COMPACT LAMINATE**

When cutting and milling Walltec facade panels, chips are produced that do not pose a risk to personal health or the environment. Therefore, this waste can be disposed of in modern thermal heating systems, which do not generate environmental toxins such as hydrochloric acid, organic chlorine compounds, or dioxins. When properly incinerated, the panels decompose into carbon dioxide, nitrogen, water, and ash. The energy produced is typically used for district heating. Additionally, disposing of the panels at organized recycling stations is straightforward.